

# CECO Mefiag

## SERIES JUMBO HORIZONTAL DISC FILTRATION SYSTEMS



15 Jumbos for P.O.P. line

### The MEFIAG® Advantage

MEFIAG® is the world's leader in the design and manufacture of filter systems utilizing horizontal disc technology for superior performance. These high efficiency, high flow systems are used in the toughest, most corrosive applications in the plating and metal finishing industry. MEFIAG's® reputation has been built over 40 years service to our customers.

### Features and Benefits

- ✓ Single chamber flow rates to 30,000 GPH
- ✓ Maximum surface area for more efficient filtration and fewer changeouts (1 sq. ft. per 100 GPH)
- ✓ Large sludge holding capacity
- ✓ Corrosion resistant construction for use in most severe applications
- ✓ Heavy duty FRP pump/1750 rpm
- ✓ CPVC plumbing
- ✓ Polypropylene discs
- ✓ Powder coated steel frame
- ✓ NEMA 4X water tight, corrosion resistant starter with soft start for non slurry filter
- ✓ NEMA 4X starter with Variable Frequency Drive (VFD) for filter with slurry option
- ✓ Temperatures to 190°F (90°C)
- ✓ Mechanical lifting device for lid

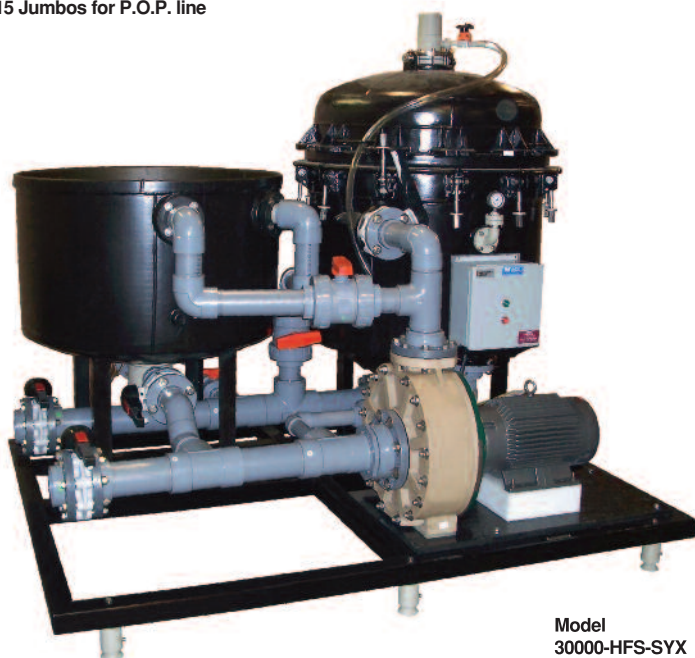

Model  
30000-HFS-SYX



Model  
30000-HFX

# Specifications

## Filter

Filter chambers are constructed of mild steel with hard rubber lining (3mm) on the interior and corrosion resistant paint on the exterior.

A flanged tangential inlet is standard, along with a bottom outlet and drain.

Stainless steel eyebolts with handwheels hold the powder coated steel cover in place. The lifting device provides for mechanical movement of the cover for maintenance purposes.

A pressure gauge (0-60 PSI) is supplied with a corrosion resistant guard.

Filter media suited for the application is placed between the rigid polypropylene filter discs. Filter media of various materials and micron ratings are available. Ten (10) micron cellulose is standard.

All systems are mounted on a powder coated structural steel frame with polypropylene feet for leveling.

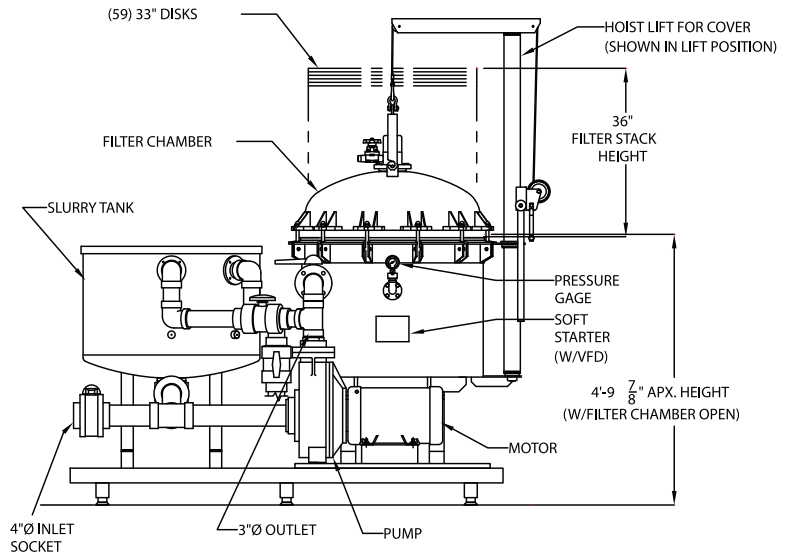

## Pump

Fyroc fiberglass centrifugal 1530 Series 4x6x10 pump with 1750 rpm, 20 h.p. motor is standard.

## Slurry Tank

Slurry tanks are mild steel construction with an interior of hard rubber (3mm) and an exterior of corrosion resistant paint. They are used to facilitate pre-coating and addition of activated carbon (if required), as well as solution make-up and priming of the pump. The slurry tank can also be used to store solution from the filter chamber during changing of media from maintenance.

Pre-coating provides superior filtration and extends the life of the filter media.

## Piping, Valves and Connections

Piping, valves, and connections are all CPVC construction.

Suction of the pump is piped to permit flow from the solution tank, slurry tank, and the filter chamber.

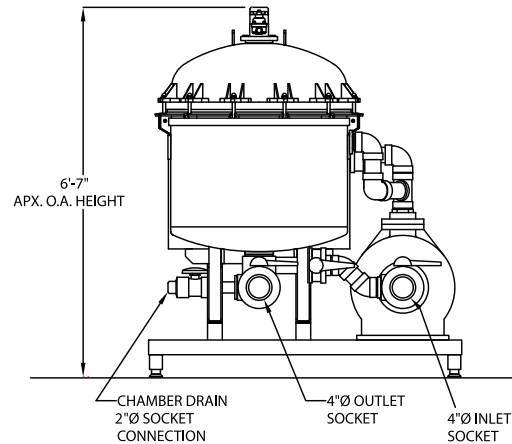

## X-Construction

X-Construction is used for more aggressive solutions such as acid copper, acid zinc, and acid tin. The filter chamber, cover and slurry tank are outside rubber lined, the base is powder coated.

## Motor Starters

Motor starters are NEMA 4X water tight, corrosion resistant with soft start. Variable frequency drive (VFD) is provided with systems that have a slurry tank.

Model	30000 HFS	30000-HFS-SY
Precoated Flow Rate (Filtering Capacity)	30,000 GPH	30,000 GPH
Open Pumping Capacity	36,000 GPH	36,000 GPH
Filtration Surface Area	347 Ft <sup>2</sup>	347 Ft <sup>2</sup>
Number of Filter Media	59 (33" Diameter)	59 (33" Diameter)
Sludge-Holding Capacity	7 Ft <sup>3</sup>	7 Ft <sup>3</sup>
Approximate Dimensions (LxWxH)	70"x70"x88"	93"x70"x88"
Approximate Crated Weight	2600 lbs.	3000 lbs.
Suction Size	4"	4"
Discharge Size	4"	4"
Motor	20 HP	20 HP

Motors are 230-460/60/3, TEFC. Mill & Chem duty and also explosion proof motors are optional. All units are supplied with bottom plate and rod w/ shackle for mechanical removal of filter stack.

# CECO Mefiag

**A Division of CECO Environmental**

700 Emlen Way • Telford, PA 18969

Phone: 215.723.8155

Email: info@ceco.com www.cecoenviro.com

Represented by: